



Inverter Welding Machine

RB360 Series



User Manual

<https://www.rebootec.com>



Dear Valued Customer,

Thank you for choosing the RB360 Series Welder. This versatile, high-performance machine is our dedicated solution for home users worldwide. Compact and portable due to its integrated design (no separate wire feeder), it packs multiple processes into one unit: Stick (MMA) welding, Scratch-Start TIG welding, MIG/MAG welding (with or without gas), and even plasma cutting, including simplified aluminum welding capability.

Built with high-quality components, each unit undergoes rigorous industry-leading laboratory testing to ensure an excellent welding experience and performance.

Minor marks from testing may be present, which is normal.

Please note: This is a high-power device. If your circuit breaker has insufficient capacity, it may trip frequently. Check for other high-power appliances on the same circuit or reduce the output power accordingly. For optimal performance, the use of genuine original accessories is highly recommended.

For your safety, please read and understand this manual thoroughly before use. Your satisfaction is our priority! For any questions or concerns, please do not hesitate to contact our support team.

	Europe and UK	service-eu@mirthtek.com	
	North America	service@mirthtek.com	
	South America and Others	nancy@weldvip-service.com	
	+86 18938887689		+86 18938887689
	Reboot Welding Solutions		+86 18923725124
	weldflowhub		https://www.rebootec.com

User Manual

Manuel utilisateur

Руководство пользователя

取扱説明書

Manuale utente

Manual de usuario

Benutzerhandbuch



Content

1. SAFETY PRECAUTIONS	3
1.1 Working Environment	5
1.2 Safety Tips	5
1.3 Symbol Explanation	6
2. Accessories that are compatible for use	6
3. TECHNICAL PARAMETERS	7
4. OPERATION AND DESCRIPTION	8
4.1 Button and Knob	8
4.2 Digital Display and Indicators	11
4.3 MMA	12
4.4 CUT	13
4.5 LIFT TIG	14
4.6 MIG Gasless	15
4.7 MIG Gas	16
4.8 Fault Code table:	17
5. INSTALLATION AND OPERATION	18
5.1 Changing Polarity	18
5.2 Input Power Connection	18
5.3 Installation and operation for MMA Welding	19
5.4 Installation and operation for plasma cutting	21
5.5 Installation and operation for TIG Welding	24
5.6 Installation and operation for Spool gun	25
5.7 Installation and operation for MIG welding	28
5.8 Installation and operation for Gasless self-shielded arc welding	31
6. BASIC KNOWLEDGE OF WELDING	32
6.1 MMA/STICK/ARC	32
6.11 Welding Process of MMA	32
6.12 Tools for MMA	33
6.13 Basic Operation of MMA	33
6.2 Flux Cored Arc Welding(FCAW)	36
6.21 Adjustable Variables	37

6.22 Basic MIG Welding	37
6.23 Travel Speed	40
6.3 GMAW	40
6.31 Classification and application of GMAW	41
6.32 GMAW Welding Equipment	41
6.33 Basic Operation of GMAW	42
6.34 Welding in Different Positions	45
6.4 plasma cutting	47
6.4.1 Pilot Cutting	47
6.4.2 Optimized Operation Guidelines	47
6.4.3 Parts in place	48
6.4.4 Pilot Arc Operation & Guidelines	48
6.4.5 Notes for cutting operation	49
7. MAINTENANCE	51
8.TROUBLESHOOTING	54
9.ELECTRICAL SCHEMATIC DIAGRAM	57
10. Warranty Registration	57

1. SAFETY PRECAUTIONS

Welding may result in injury to you and others, so please implement protection during welding. See more details in Safety Protection Guidebook for Operator which meets the requirements to manufactures on accident prevention.

Operate this equipment by trained professional only!



- Use welding labor protection supplies with approval of safety supervisory authority!
- Operators must be the special workers with valid work permits of “Metal Welding (Gas Cutting) Operation”!
- Do not maintain and repair welder with power.

Electric shock-may result in serious injury or even death!



- Install grounding device according to application standard.
- Do not touch live parts with naked skin, wet gloves or wet clothes.
- Be sure you are insulated from ground and workpiece.
- Confirm the safety of your working position.

Smoke-may be harmful to your health!



- Keep your head away from the smoke to avoid inhalation of waste gas in welding.
- Keep the working environment well ventilated with exhaust or ventilation equipment when welding.

Arc radiation-may hurt your eyes and burn your skin!



- Use proper welding mask and wear protective clothing to protect your eyes and body.
- Use proper mask or curtain to protect onlooker from being injured.

Improper use and operation may result in fire or explosion



- Welding spark may result in fire, so please make ensure there are no inflammables near the welding position, and pay attention to fire safety.
- Ensure there is fire extinguisher nearby, and make sure someone has been trained to operate the fire extinguisher.
- Do not weld closed container.
- Do not use this machine for pipe thawing.

Hot workpiece can cause severe scald.



- Do not touch hot workpiece with bare hands.
- Cool the welding torch for a while after continuously working.

Excessive noise does great harm to people's hearing.



- Wear ear covers or other hearing protectors when welding.
- Give warning to onlooker that noise may be potentially hazardous to hearing.

Magnetic field can make cardiac pacemaker a bit wonky.



- People with cardiac pacemaker should stay away from the welding spot without first talking to a doctor.

Moving parts may injure your body.



- Please keep away from moving parts (like fan).
- Each door, panel, cover, baffle plate, and protective device the like should be closed and located correctly.

Seek professional support when trouble strikes.



- When trouble strikes in installation and operation, please inspect according to related contents in this manual.
- If you still cannot understand fully, or you still cannot solve the problem, please contact the dealer to obtain professional support.

WARNING



Replacing the components can be dangerous.

- Only professionals can replace the machine components.
- Make sure there is nothing left such as wire leads, screws, gaskets and metal bars in the machine when replacing the components.
- Make sure the internal connection of machine is correct after replacing the PCBs, and then the machine can be operated. Otherwise, machine may be damaged.

Precautions for scrapping

Pay attention to the following when discarding the welding machine:

- Burning the electrolytic capacitors in the main circuit or on the PCBs may cause an explosion.
- Burning plastic parts like front panel will result in toxic gases.
- Dispose the machine as industrial waste.

1.1 Working Environment

- The installation should be performed in place which can withstand the weight of the welding machine.
- Installation should not be performed in place where water splash may happen such as water pipe.
- Welding should be carried out in dry environment with humidity of 90% or less.
- The temperature of the working environment should be between -10°C and 40°C.
- Welding should not be performed in sunlight or rain. Keep it dry at all times.
- Welding should not be performed in dusty area or environment with corrosive chemical gas.
- Gas shielded arc welding should be operated in environment without strong airflow.
- Welding should not be performed on a platform with slope of more than 10°

1.2 Safety Tips

- Make sure good ventilation.

This welder can create powerful welding current that has strict cooling requirements that cannot be met with natural ventilation. Therefore the internal fan is very important in enabling the machine to work steadily with effective cooling. The operator should make sure that the louvers be uncovered and unblocked. The minimum distance between the machine and nearby objects should be 30cm. Good ventilation is of critical importance to the normal performance and lifespan of the machine.

- Overload is forbidden.

Welder should be operated according to allowable duty cycle (refer to the duty cycle table). Make sure that the welding current should not exceed the max load current. Overload could obviously shorten the machine's service life, or even damage the machine.

- Over-voltage is forbidden.



Regarding the power voltage, please refer to "Technical Parameters" table. This machine is of automatic voltage compensation, which ensures welding current is

within allowable range. In case that the power voltage exceeds the allowable value, it would damage the machine. Operators should be fully aware of such situation and take according precautions.

- The power cord of a welder has a yellow/green ground cable.

Before operation, we'll connect the ground cable to GND to discharge static electricity or prevent accidents caused by static electricity. A sudden halt may occur with digital display showing "E02" on the front panel if the machine is in over-load triggering temperature switch. Under this circumstance, it is unnecessary to unplug the power plug so that the fan keeps working to cool down the machine. Welding can be continued after the inner temperature falls into the standard range and "E02" is off.

1.3 Symbol Explanation

<p>WARNING</p> 	<p>Matters to be noticed in operation</p>		<p>It is prohibited to dispose the electrical waste together with other common wastes. Please protect the environment.</p>
	<p>Objects to be specially described and pointed out</p>		



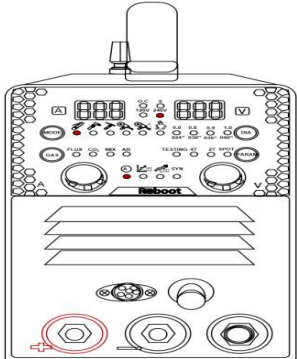
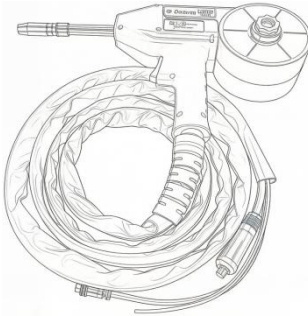
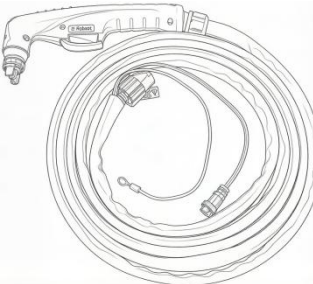

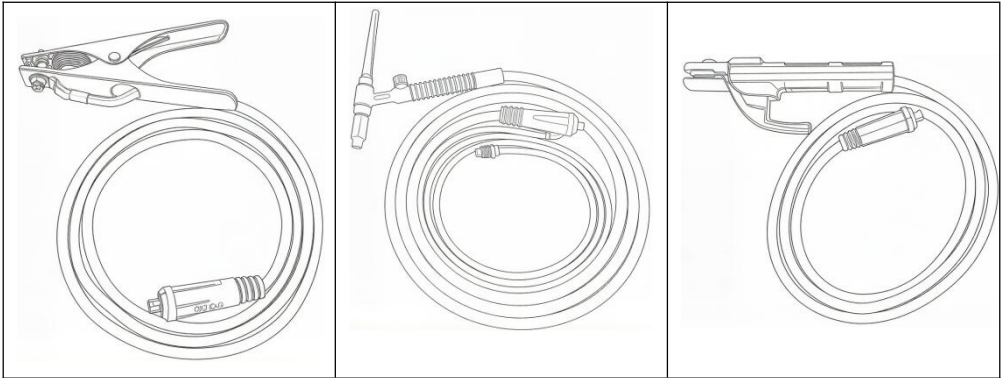





2. Accessories that are compatible for use

<p>Note: May not be included as standard equipment</p>		
Machine	Spool gun	PT40
		
<p>Earth Clamp</p>	<p>17V TIG Torch</p>	<p>Electrode Holder</p>

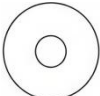

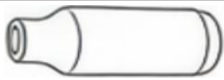
Replacement Parts:

For optimal performance, the use of genuine original accessories is highly recommended. Please log in to the official website: WWW.REBOOTEC.COM

			
			
			
Nozzle	Electrode	Contact Tip	Drive Roller
Wire Recoil Spring	Flat Washer	Spacer Nut	Quick Connect Air Fitting
Nozzle / Cup	Collet Body	Collet	Tungsten Electrode

3. TECHNICAL PARAMETERS





TECHNICAL PARAMETERS		RB360 Series	
Rated input voltage(V)		Single-phase AC100V~120V 50/60Hz	Single-phase AC200V~240V 50/60Hz
Rated input power(KVA)		4.1	5.7
Rated input current(A)		35	25
Welding	MMA	20~110	20~130
	CUT	15~25	15~30



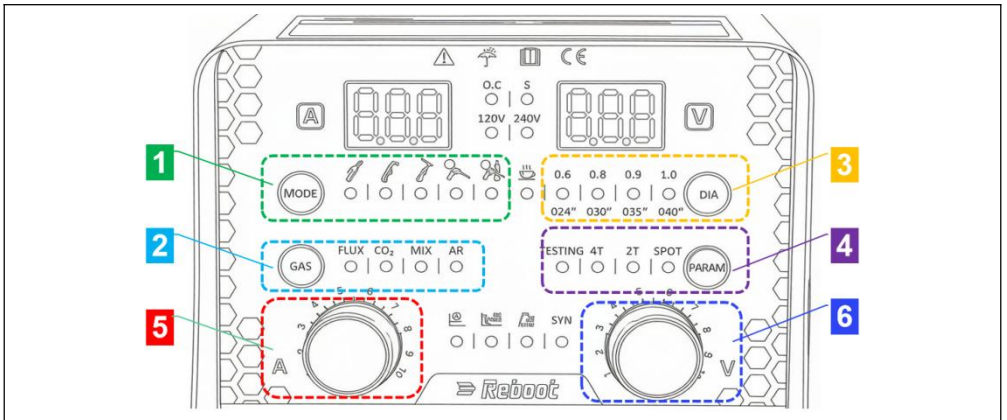

current range(A)	LIFT TIG	20~110	20~130
	MIG	20~110	20~130
No-load voltage		65V/CUT 330V	
Wire feed Speed		(2.0~13m/min) /(79~513IPM)	
Applicable Electrode(MMA)	1/16" 3/25" 1/8"		
	1.6mm/2.5mm/3.2mm		
Applicable Electrode(MIG)	.024"/.030"/.035"/.040"		
	0.6mm/0.8mm/0.9mm/1.0mm		
Size		427*134*255mm ³ /16.81*5.28*10.04" ³	
Weight		11.57lb/5.25kg	
Rated duty cycle		60%	
Overall efficiency		85%	
Protection grade		IP21S	
Power factor		COSφ=0.72	
Insulation grade		F	

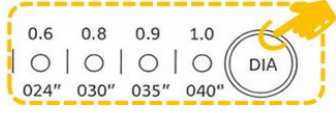
4. OPERATION AND DESCRIPTION

4.1 Button and Knob

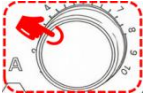

1	Mode Switching	 <p>Press the MODE button to cycle through the functions: MMA → CUT → LIFT TIG → MIG GASLESS → MIG GAS</p>
2	Gas Selection	 <p>In MIG mode, press the Gas button to cycle through the gas types: FLUX → CO₂ → MIX → AR</p>
3	Wire Diameter Selection	 <p>In MIG mode, press the DIA. button to cycle through the wire diameters: 0.6mm → 0.8mm → 0.9mm → 1.0mm (.024" → .030" → .035" → .040").</p>
4	Parameter Switch	 <p>TESTING: Open the gas valve for 5 seconds to allow the user to check the gas flow.</p> <p>4T: Initiate Weld (Press and hold the torch switch to start the welding sequence) → Maintain Weld (Release the switch; cutting will continue without needing to hold the trigger) → Prepare to Stop (Briefly press the torch switch again. The system is now ready to stop) → Stop Welding (Release the switch to end the cutting cycle and shut down the arc)</p> <p>2T: Initiate welding (Press and hold the torch switch to activate the welding arc) → Stop welding (Release the switch to immediately deactivate the arc and exit welding mode)</p> <p>SPOT: The welding process automatically stops once the continuous welding duration reaches the set time. The switch must be restarted to initiate the next cycle.</p> <p>Press the PARAM button to cycle through 4T → 2T → SPOT. Press</p>

		<p>and hold the PARAM button for 3 seconds to directly enter the TESTING state, allowing the user to check for gas output. It will automatically exit the TESTING state and return to the previous state after 5 seconds.</p> <p>Note: The available options may vary slightly depending on the selected function.</p>	
5	Current knob A		In MMA mode, press knob A to cycle through Operating Status→ARC FORCE Setting→HOT START Setting.
			Press and hold knob A for 3 seconds to turn the Current Limit mode on or off.
			Rotate knob A to adjust either the welding current (in Operating Status) or the corresponding parameter value (in a setting mode)
			In Manual (non-synergic) MIG mode, rotate knob A to adjust the wire feed speed within a range of 2.0 to 13.0 meters per second (m/s).
6	Voltage knob V		In CUT mode, press knob V to enter or exit the gas post-flow time setting state.
			In MIG mode, press knob V to turn the SYN function on or off
			In SPOT mode, press and hold knob V for 3 seconds to enter or exit the SPOT parameter setting state.
			In the gas post-flow time setting state of CUT mode, rotate knob V to set the post-flow time within a range of 2.0 to 15.0 seconds.
			In Synergic MIG mode, rotate knob V to fine-tune the output voltage within a range of -3 V to +3 V.
			In Manual MIG mode, rotate knob V to adjust the output voltage.
		In the SPOT parameter setting state, rotate knob V to set the SPOT welding time from 0.1 to 10.0 seconds.	

4.2 Digital Display and Indicators

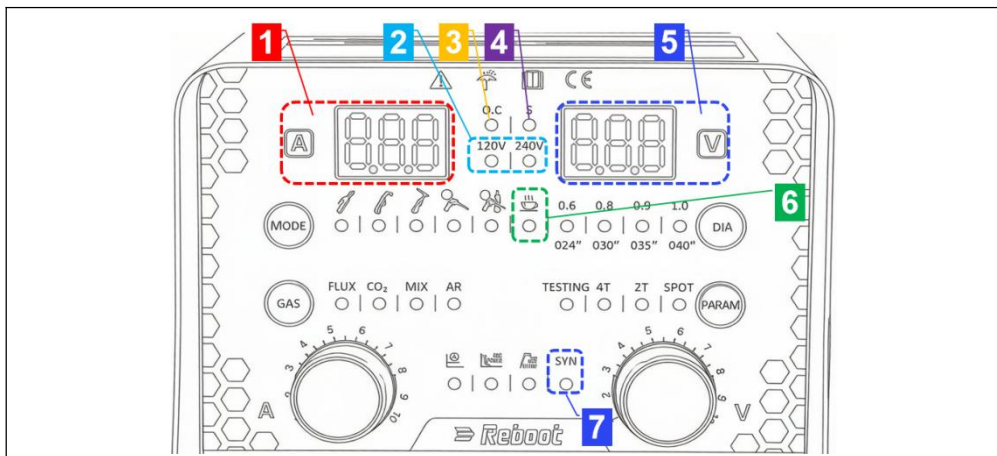

1	Current Digital display	Current Display
		Wire feed speed Display
		Error Code Display
		Parameter setting for “arc force”/”Hot Start” Display
2	Input Voltage	Input Voltage 120V LED (AC Input 100~120V 50~60Hz)
		Input Voltage 240V LED (AC Input 200~240V 50~60Hz)
3	Fault Indicator	When the machine stops operating due to a fault, the Fault Indicator lights up.
4	s (seconds) Indicator	
5	Voltage Digital display	Voltage Display
		Displays the output voltage deviation during adjustment.
		Display Spot Welding Time Setting
		Display Gas Post-flow Time
6	REST Indicator	Rest Alert: Activated after 40 minutes of cumulative operation per hour.
	Current Limit	Press and hold knob A for 3 seconds to turn the Current Limit mode on or off. In Current Limit mode, the maximum output current of the device will be restricted, which helps prevent the standard plug fuse from blowing or the circuit breaker from tripping. For better welding capability, when operating in full power mode, ensure that the power

		input meets the device requirements (see the "Input Power Connection" section). Notice: This feature is specifically designed for certain regions. If your unit does not include this feature, it is not a defect or malfunction.
7	SYN	Synergic MIG automatically matches current and voltage parameters, simplifying the process by eliminating the need for manual matching. In MIG mode, press knob V to turn the SYN function on or off.

4.3 MMA

Operating Status		
1	Press the MODE button to switch the program to the MMA state, as shown in the figure below.	
2	In the operating status shown in the figure, rotate knob A to adjust the output current	
3	Display Preset Output Current	
Arc Force Setting		
1	In MMA mode, Press the Knob A to switch the program to the Arc Force state, as shown in the figure below.	
2	In the arc force setting mode, "knob A" adjusts the arc force parameter value, with an adjustment range of 0~10.	
3	Display arc force parameter value	
Hot Start Setting		
1	In MMA mode, Press the Knob A to switch the program to the Hot Start state, as shown in the figure below.	

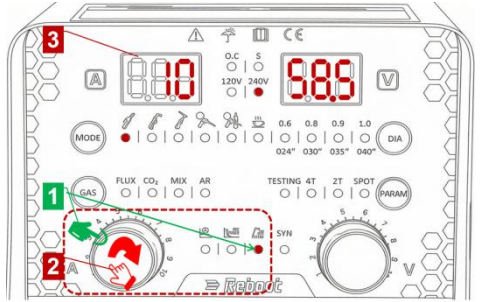
2	In the Hot Start setting mode, “knob A” adjusts the Hot Start parameter value, with an adjustment range of 0~10.	
3	Display Hot Start parameter value	

4.4 CUT

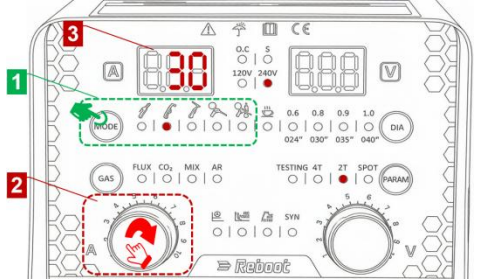
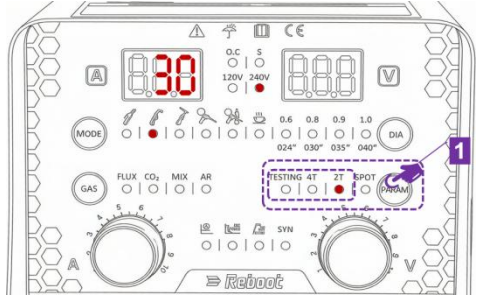
Operating Status		
1	Press the MODE button to switch the program to the cut state, as shown in the figure below.	
2	In the operating status shown in the figure, rotate knob A to adjust the output current	
3	Display Preset Output Current	
Function Selection		
2T	In CUT mode, press the PARAM button to switch the function to 2T.	
4T	In CUT mode, press the PARAM button to switch the function to 4T.	
TESTING: Press and hold the PARAM button for 3 seconds to directly enter the TESTING state, It will automatically exit the TESTING state and return to the previous state after 5 seconds.		
Post-flow Time Setting		
1	In CUT mode, Press knob V to turn on or off the post-flow time setting, and the Seconds indicator will	

	illuminate.as shown in the figure below.	
2	Rotate knob V to adjust the post-flow time, with an adjustment range of 2.0~15.0 seconds.	
3	Display post-flow time value	

4.5 LIFT TIG

Normal Operating Status		
1	Press the MODE button to switch the program to the LIFT TIG state, as shown in the figure below.	
2	In the operating status shown in the figure, rotate knob A to adjust the output current	
3	Display Preset Output Current	
SPOT Operating Status		
1	In LIFT TIG mode, press the PARAM button to enter or exit SPOT welding mode, as shown in the figure below.	
2	Rotate knob A to adjust the output current	
3	Display Preset Output Current	
SPOT SETTING Status		
1	In LIFT TIG mode, press the PARAM button to enter SPOT welding mode, as shown in the figure below.	

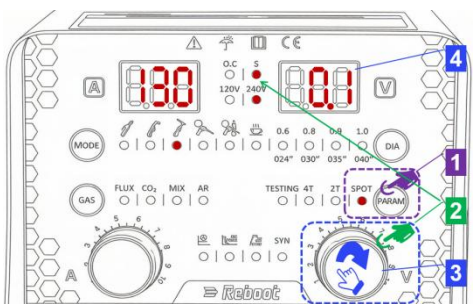
2	When the SPOT function is enabled, Press and hold knob V for 3 seconds to enter or exit the SPOT setting interface, and the Seconds indicator will illuminate.	
3	Rotate knob V to adjust the SPOT parameter value, with an adjustment range of 0.1~10.0 seconds.	
4	Display the SPOT parameter value.	

4.6 MIG Gasless

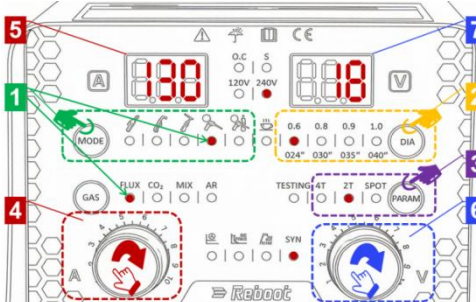
SYN Operating Status		
1	When the MODE button is pressed to switch the program to MIG GASLESS, the gas type is automatically locked to the FLUX position	
2	Press the DIA button to switch between wire diameters. The available diameters are 0.6 mm, 0.8 mm, 0.9 mm, and 1.0 mm. Output voltage may vary accordingly depending on the selected wire diameter.	
3	Press the PARAM button to cycle through the 4T, 2T, and SPOT modes. To set SPOT parameters in MIG mode, please refer to the SPOT parameter setting in LIFT TIG mode.	
4	Rotate knob A to adjust the output current	
5	Display Preset Output Current	
6	Rotate knob V to fine-tune the output voltage within a range of -3 V to +3 V. After adjusting, the voltage display shows the set value for 3 seconds before	

	reverting to the actual output voltage.
7	Voltage Display or Displays the output voltage deviation during adjustment.
In Manual (non-synergic) MIG Operating Status	
1	In MIG Gasless mode, press knob V to turn the SYN (Synergic) MIG mode on or off. In non-synergic (manual) mode, the gas and wire diameter selections are unavailable. Simultaneously, the current display changes to show the wire feed speed.
2	Press the PARAM button to cycle through the 4T, 2T, and SPOT modes.
2	To set SPOT parameters in MIG mode, please refer to the SPOT parameter setting in LIFT TIG mode.
3	Rotate knob A to adjust the wire feed speed, with a range of 2.0~13.0 meters per minute.
4	Wire feed speed Display.
5	Rotate knob V to adjust the output voltage
6	Voltage Display

4.7 MIG Gas

SYN Operating Status	
1	Press the MODE button to switch the program to the MIG Gas state, as shown in the figure below.
1	Press the GAS button to cycle through CO ₂ , MIX, and AR. FLUX is not available for selection.
2	CO ₂ refers to C100 (100% CO ₂), and MIX refers to C20 (20% CO ₂ , 80% Ar).
2	The AR channel is specifically designed for aluminum welding. When the gas is

	set to AR, the wire diameter is automatically locked at 1.0 mm, supporting the welding of aluminum-magnesium and aluminum-silicon alloys. The voltage can be fine-tuned via knob V to achieve optimized aluminum welding results.
3	When the gas type is not set to AR, press the DIA button to select from the available wire diameter parameters.
4	Press the PARAM button to cycle through the 4T, 2T, and SPOT modes.
	Press and hold the PARAM button for 3 seconds to directly enter the TESTING state, It will automatically exit the TESTING state and return to the previous state after 5 seconds.
	To set SPOT parameters in MIG mode, please refer to the SPOT parameter setting in LIFT TIG mode.
5	Rotate knob A to adjust the output current
6	Display Preset Output Current
7	Rotate knob V to fine-tune the output voltage within a range of -3 V to +3 V. After adjusting, the voltage display shows the set value for 3 seconds before reverting to the actual output voltage.
8	Voltage Display or Displays the output voltage deviation during adjustment.
In Manual (non-synergic) MIG Operating Status	
The operating procedure for non-synergic (manual) MIG/MAG welding with shielding gas is the same as for non-synergic gasless (FCAW) MIG welding. Please refer to the relevant section for FCAW operation.	

4.8 Fault Code table:

Digital tube display code	Code meaning
E01	Overheat Protection: Excessive temperature will trigger the overheat protection alert.
E02	Overvoltage Protection: When operating at 120V, overvoltage protection is triggered if the input exceeds 150-155V AC.
E09	Short Circuit Protection: Activated on electrode / workpiece contact; resumes automatically when separated.

5. INSTALLATION AND OPERATION

Note: Please install the machine strictly according to the following steps. Turn off the power supply switch before any electric connection operation. The housing protection grade of this machine is IP21S, so do not use it in rain.

5.1 Changing Polarity

In inverter welding, the output current flows from the positive electrode, through the workpiece, to the negative electrode. The positive pole possesses greater energy. Consequently, with DCEP (Direct Current Electrode Positive), the heat is concentrated on the electrode/gun side. With DCEN (Direct Current Electrode Negative), the heat is concentrated on the workpiece side.

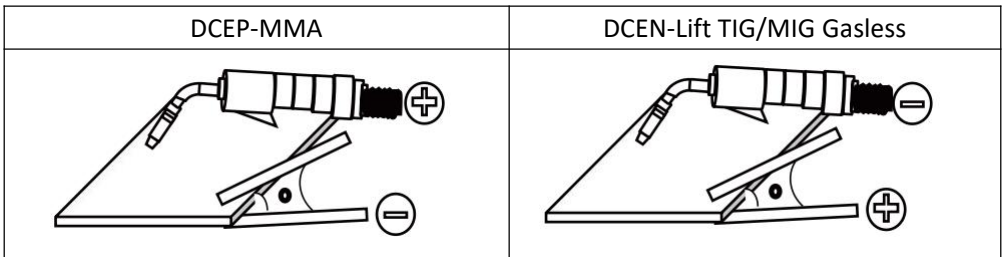
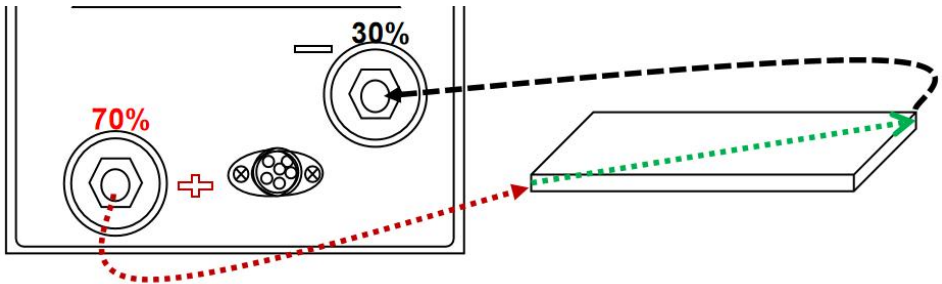



5.2 Input Power Connection

- A primary power supply cable is available for this welding machine. Connect the primary power supply cable to the corresponding voltage class based on rated input power of the welder. Misconnection should be avoided.
- The primary cable should be tightly connected to the corresponding power binding post or socket to avoid oxidation.

- Check whether the input voltage value varies in acceptable range with a multi-meter.

The Machine operates in 110V/220V power supply. Plug the Power Cord into a properly grounded. Set torch down on nonconductive, nonflammable surface away from any grounded objects. And then then turn the Power Switch ON. The fan should start. The Digital screen should turn on.

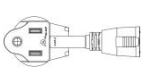
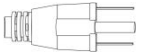
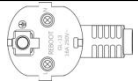
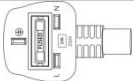
NOTICE: Adjust the Voltage Switch to match the outlet voltage:

America Plug	
For 220VAC, attach the provided adapter to the Power Cord.	
For 110VAC, do not use the adapter. Plug the Power Cord into a properly grounded and rated receptacle matching the plug and selected voltage. Need to be connected to circuits with 50A and above circuit breakers.	
European Plug	
When operating at maximum current, a circuit breaker with an insufficient current rating may trip. Please confirm that your circuit breaker is rated for 25A or higher.	
British Plug	
For a 13A fused plug: To prevent the fuse from blowing, ensure the cutting current does not exceed 23A.	
For optimal cutting performance and to utilize the machine's full capacity, the power input must be upgraded. This work must be performed by a qualified electrician. The standard 13A plug should be replaced with either a dedicated 16A industrial plug and socket, or the unit should be hardwired directly to the supply. Furthermore, the circuit must be protected by a dedicated breaker with a rating greater than 25A.	

5.3 Installation and operation for MMA Welding

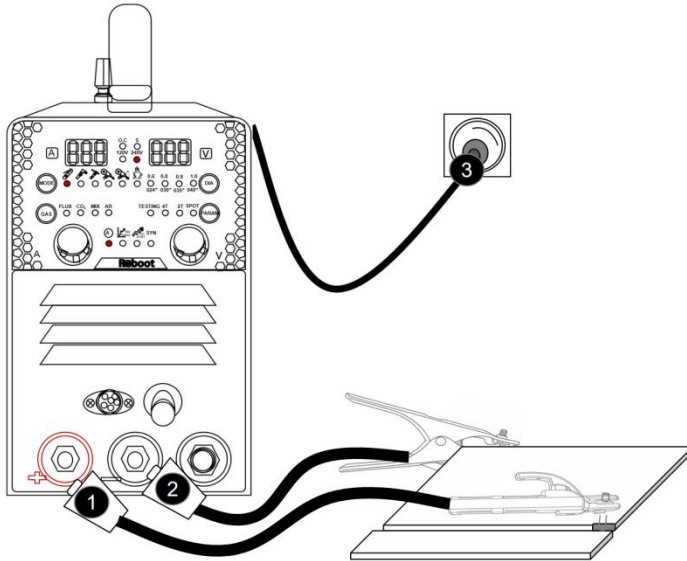

- | | |
|---|--|
| 1 | Insert the cable plug with electrode holder into the “+” socket on the front panel of the welding machine, and tighten it clockwise. |
| 2 | Insert the cable plug with ground clamp into the “ - ” socket on the front panel of the welding machine, and tighten it clockwise. |
| 3 | Connect the power ground well. |

The connection method described above is DCEP (Direct Current Electrode Positive). For acid electrodes, the DCEN (Direct Current Electrode Negative) connection method can also be used.

Operation

- | | |
|---|--|
| 1 | After being installed according to the above method, and the power switch being switched on, the machine is started with the power LED on and the fan working. |
| 2 | Pay attention to the polarity when connecting. There are two ways of wiring on DC welder: DCEN and DCEP. DCEN: welding holder connected to “-” and work piece to “+”; DCEP: workpiece to “-” and welding holder to “+”. Please choose the proper connection method according to different workpiece and processing methods. Unstable arc, spatter, and electrode sticking could happen if improper polarity is selected. Please change the polarity by exchanging the quick connector in case of above abnormal situation. |

3	When switching the welding mode to MMA, welding can be carried out with output current in rated range.
4	Select cable with larger cross-section to reduce the voltage drop if the workpiece is far away from the welder with long secondary cables(welding cable and earth cable).
In MMA mode, press knob A to cycle through: Operating Status → ARC FORCE Setting → HOT START Setting. Rotate knob A to adjust the welding current or the corresponding parameter value.	

Preset the welding current according to the type and size of the electrode, clamp the electrode and then welding can be carried out by short circuit arc ignition. For welding parameters, please refer to the following table.

Welding parameters table (for reference only)

Note: This table is suitable for mild steel welding For other materials, consult related materials and welding process for reference

	Material Thickness	3mm	4mm	5mm
	Electrode Diameter	Recommended Welding Current(A)		
6010	3/31"(2.5mm)	65~85	85~115	115~130
	1/8"(3.2mm)	95~115	115~130	130
6011	3/31"(2.5mm)	65~85	85~105	105~125
	1/8"(3.2mm)	85~115	115~130	130
6013	3/31"(2.5mm)	65~85	85~115	115~130
	1/8"(3.2mm)	75~95	95~125	130
7018	3/31"(2.5mm)	85~105	105~125	130
	1/8"(3.2mm)		130	130

5.4 Installation and operation for plasma cutting

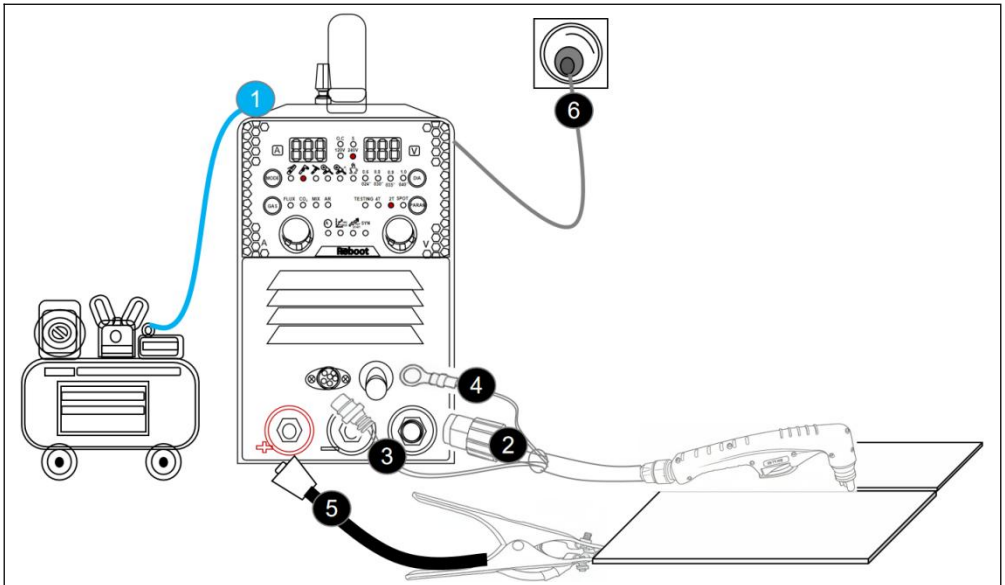

Connection of air compressor

The plasma cutter requires compressed air to be attached to the unit. Due to potential differences in standards between the air compressor supply line and the quick-connect fitting, the connection can be bridged by splicing in a section of high-pressure air hose using hose clamps. Ensure the clamps are tightened securely to prevent air leaks.

Install the regulator with arrows for Inlet/Outlet. Incorrect connection blocks flow. Input pressure: 30–100 Psi. A compressor $\geq 750\text{W}$ and a **flow rate within the range of 6.4 to 7.1 CFM** is recommended.

The included regulator is pre-set to 30–70 Psi.

The air filter captures water/oil vapor; drain condensate via the bottom valve.

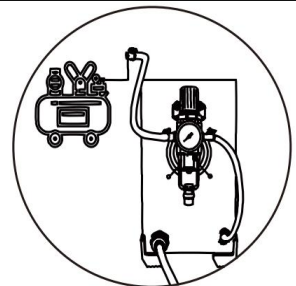

1

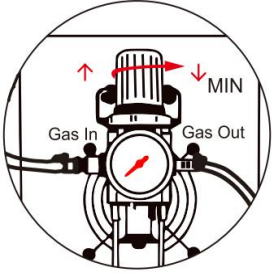
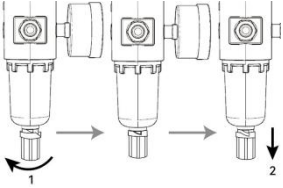
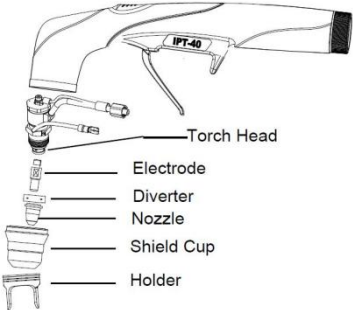
<p>Steps for reducer setting are as follows:</p> <ol style="list-style-type: none"> 1. lift the pressure control knob upward. 2. adjust the gas pressure to the desired value by rotating the knob (rotate to “+” direction to increase gas pressure; rotate to “-” direction to reduce gas pressure); 3. press down the pressure control knob to get the knob locked. 	
<p>Release water and oil vapor or gas WARNING: DO NOT set up without SWITCH OFF !</p> <ol style="list-style-type: none"> 1. Turn the knob to the left to open the drain knob. 2. Pull the drain knob down to Release water and oil vapor or gas. 	
<p>NOTICE: The drain knob needs to be turned off before the machine can be used properly.</p>	
<p>Installation of the cutting torch Check the torch for proper assembly. Install proper torch parts for the desired application.</p>	
<ol style="list-style-type: none"> 1. Connect the Electrode into the Torch Head. 2. Connect the Diverter into the Torch Head. 3. Connect the Nozzle into the Electrode. 4. Connect the Shield Cup into the Torch Head. 5. Connect the Wire Spacer Guide onto Shield Cup. <p>NOTE: The power supply will NOT operate unless the torch shield cup is fully seated against the Parts in Place pins in the torch head.</p> <p>Ensure all components are securely fastened. Loose installation may result in arc ignition failure.</p>	
<p>2</p>	<p>Connect the Cutting gun to “-” Negative polarity. Slide the protective shroud on the torch cable end fully forward onto the machine panel. This ensures the electrical connection is completely enclosed for proper safety protection.</p>
<p>3</p>	<p>Connect the aviation plug to switched torch connector on the front panel.</p>

4	Connect the Pilot Arc Cable to Pilot Arc Terminal.
NOTICE: The Cutting gun connector MUST be tightly connected to the socket to avoid power short circuit. Slide the barrel shroud back until it clicks into place, covering the connection.	
5	<p>Connection of earth cable</p> <p>Insert the quick plug on the earth cable into the output terminal “+” on the front panel of the machine, and tighten it clockwise.</p> <p>NOTICE: The ground clamp connector MUST be tightly connected to the socket to avoid power short circuit.</p> <p>Ensure the ground clamp is connected on clean, bare metal (not rusty or painted).</p>
6	Connect the power ground well.
Please refer to Section 4.4 CUT for further parameter configuration.	

5.5 Installation and operation for TIG Welding

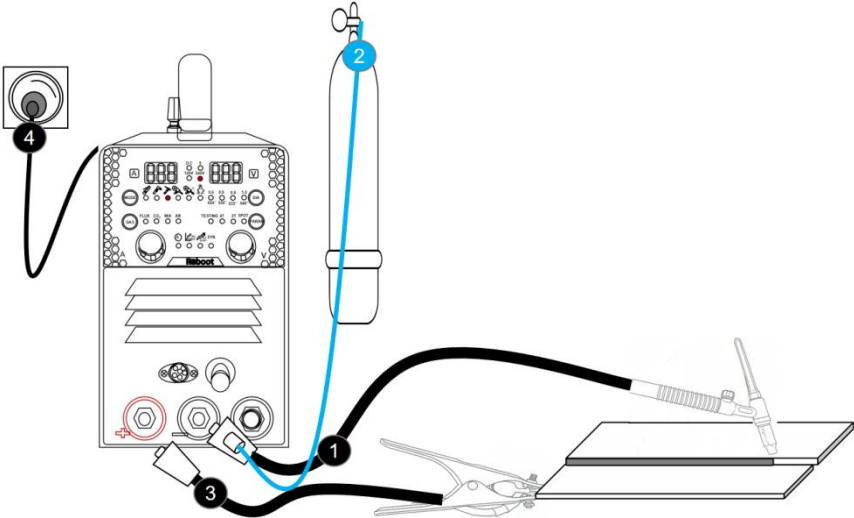
	
1	Insert the cable plug with tig torch into the “-” socket on the front panel of the welding machine, and tighten it clockwise.
2	Connect Argon cylinder and gas inlet hose of TIG torch. Open the gas valve after achieving suitable gas flow. Attention: Make sure connection is well to prevent gas leakage. (Note: At TIG, gas is not controlled by built-in gas valve; therefore,

	gas should be connected to gas inlet hose of TIG torch outside the machine)
3	Insert the cable plug with ground clamp into the “+” socket on the front panel of the welding machine, and tighten it clockwise.
4	Connect the power ground well.

Operation

1	After being installed according to the above method, and the power switch on the rear panel being switched on, the machine is started with digital display on and the fan working.
2	Select “TIG” as the welding mode.
3	According to workpiece thickness, select welding current by adjusting “current adjusting knob” and ammeter displays this set value. The gas flow can then be regulated via the switch on the torch handle.
4	Arc starting method: As this machine adopts touch start TIG, operator can start normal welding by slightly raising the torch when there is current after the tungsten is touching the workpiece.

Please refer to Section 4.5 LIFT TIG for further parameter configuration.

Welding parameters table (for reference only)

Note: TIG welding must only be performed using 100% argon gas for shielding.

Material Thickness	1mm	2mm	3mm	4mm	5mm
Electrode Diameter	Recommended Welding Current(A)				
1/16"(1.6mm)	20~30	30~45	45~80	80~100	100~130
3/31"(2.5mm)	30~40	40~55	55~80	80~110	110~130

5.6 Installation and operation for Spool gun

Spool Gun: It is widely employed in aluminum welding applications.

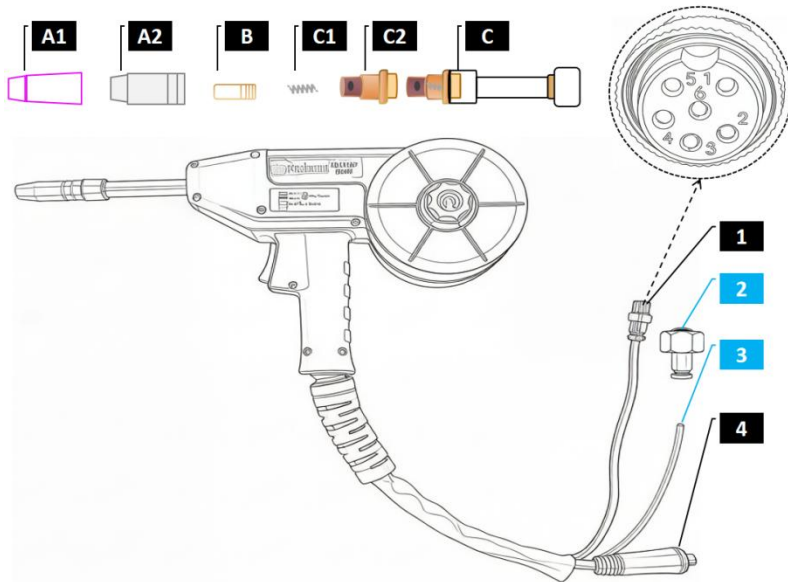

1	6 Pin Aviation Plug	1	This pin is designed to be shorted to pin 2
		2	This pin is designed to be shorted to pin 1
		3	Wire Feed Motor DC (+)
		4	Wire Feed Motor DC (-)
		5	Connect one end of the torch trigger control wire
		6	Connect the other end of the torch trigger control wire

M16 to Quick Connect Air Fitting
 For MIG GAS operation, this accessory connects the M16 gas outlet on the machine's front panel to the gas hose of the welding torch. It includes an integral seal; if missing, gas leakage may occur.
 This component is provided as standard equipment with the machine.

3 4x2.5mm High-Pressure Air Line

4 10-25 mm² EURO Fast Lock Connector

Replacement Parts:

A1	Ceramic nozzle ϕ 12mm	A2	Gas nozzle ϕ 12mm
B	Contact tip ϕ 0.6,0.8,0.9,1.0 mm/M6*25	C	Torch head
C1	Gas diffuser	C2	Nozzle spring

This MIG welder automatically detects the spool gun. When the original

factory-supplied pool gun is connected, the machine will automatically switch to pool gun mode in MIG mode.

Welding Wire Install

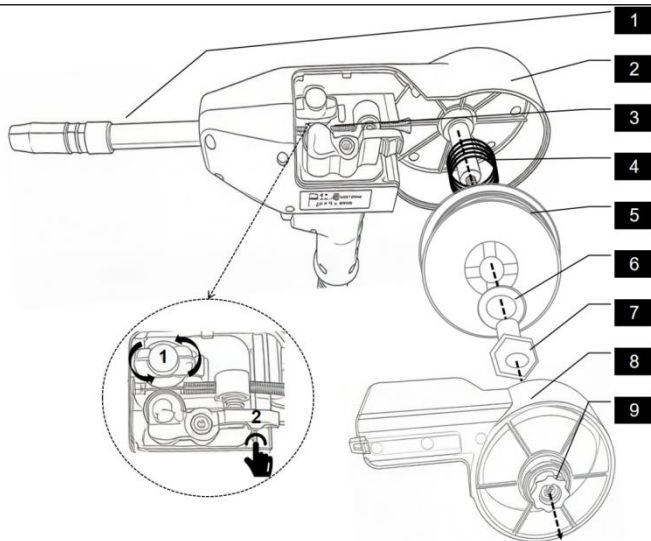

1



Remove the gas nozzle or ceramic nozzle from the torch head by turning it clockwise. Then, unscrew and remove the contact tip from the torch head. **For aluminum welding, use a contact tip one size larger.**

2

Loosen the protection cover nut and remove the cover.

3

Correct Operation of the Wire Feeder

3.1 Check and install the correct drive roll. To change the drive roll, rotate the retaining cover 45° counterclockwise to remove it. Typically, a V-groove drive roll is used for solid wire, a knurled drive roll for flux-cored wire, and a U-groove drive roll for aluminum wire. **To enhance the user experience, a universal drive roll compatible with all wire types is supplied as standard equipment.**

3.2 Pull out a 10-15 cm length of wire from the spool. Thread the wire into the wire inlet guide of the feeder. Press down on the tension lever/arm of the feeder, feed the wire through the drive roll and into the torch liner, then release the tension lever. Ensure the wire is securely seated in the groove of the drive roll.

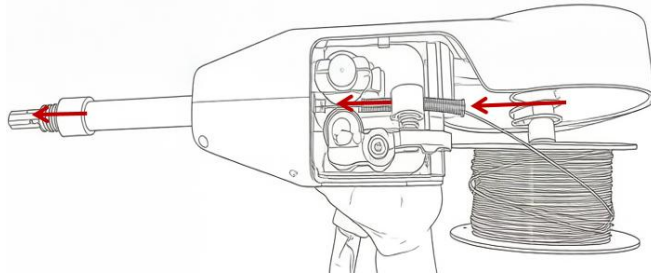

- | | |
|---|--|
| 4 | Thread the wire recoil spring onto the spindle. |
| 5 | Place the wire spool onto the spindle, compressing the wire recoil spring. |
| 6 | Place the flat washer onto the spindle, pressing it against the side of the spool. |
| 7 | Thread the spacer nut onto the spindle counterclockwise until the spool no longer has free play. |
| 8 | Practice a few times to master the process. After the wire is loaded, reinstall the protection cover onto the spool gun. |
| 9 | Tighten the protection cover nut. |

Note: In MIG mode, not during welding, press torch trigger for at least 3S, the welder will go in fast inching status, closing output port voltage and gas valve. Release torch trigger, the welder will stop inching.

5.7 Installation and operation for MIG welding

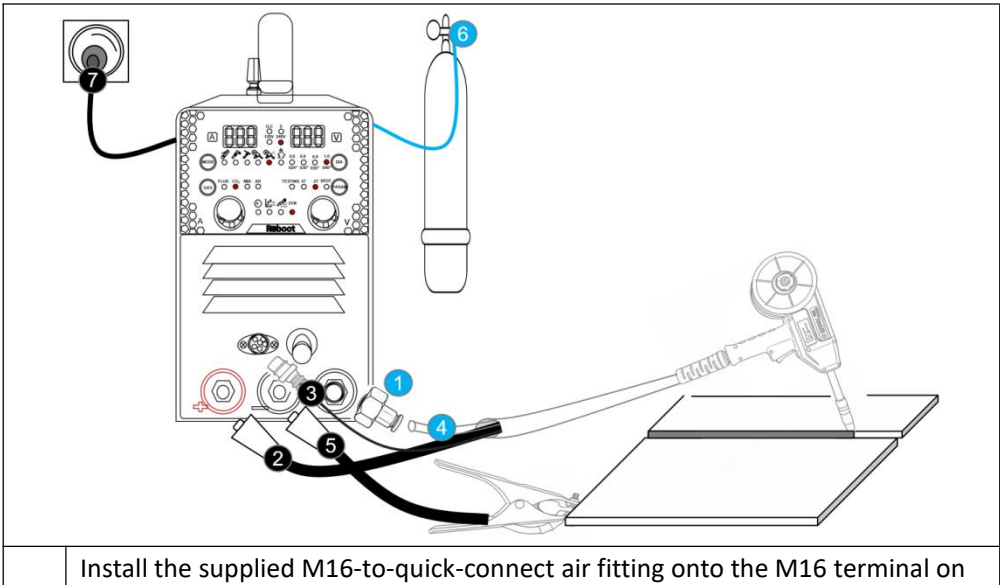

Install the supplied M16-to-quick-connect air fitting onto the M16 terminal on

1	the machine's front panel and tighten it securely. Pay special attention to the sealing washer inside the adapter; if missing, it will result in gas leakage.
2	Connect the 10-25 EURO quick-connect plug of the Spool gun to the positive (+) terminal on the machine's front panel and tighten it clockwise.
3	Connect the 6-pin aviation connector of the Spool gun to the corresponding port on the machine's front panel and tighten the locking nut.
4	Insert the air hose of the Spool gun into the quick-connect coupling until it clicks into the fully locked position. To disconnect, press the blue collar of the coupling and then pull the hose out.
5	Insert the cable plug with work clamp into the "-" output terminal on the front panel of the welding machine, and tighten it clockwise.
6	Connect the cylinder equipped with the gas regulator to the gas inlet on the rear panel of the machine with a gas hose. Note: MIG shielding gas and plasma cutting gas share a common inlet passage. Connect the shielding gas supply line to the quick-connect inlet on the pressure regulator. (Due to potential differences in hose and connector standards, users can bridge the connection by splicing a section of high-pressure air hose using hose clamps.) Please check the drain valve at the bottom of the regulator for any leaks.
7	Connect the power ground well.
<p>Note: Install the wire spool on the spindle adapter. Make sure that the groove size of wire feed roll matches the contact tip size of the welding torch and the wire diameter being used. Release the pressure arm of the wire feeder to thread the wire through the liner, into the roll groove and then into the liner of central connector. Adjust the pressure arm to ensure no sliding of the wire. Too high pressure will lead to wire distortion, which will affect wire feeding. Press the Inching button to thread the wire out of the contact tip on the torch. Please refer to the welding Wire Installation section.</p>	
Operation	
1	After being installed according to the above method, and the power switch being switched on, the machine is started with digital display on and the fan working. Open the cylinder valve, and adjust the flow regulator to get the proper gas flow.

2	<p>Press 2T/4T button to select desired mode.</p> <p>2T:Press torch trigger to activate wire feeding.After arc ignition,start welding based on set wire feed speed and voltage.Release torch trigger to stop wire feeding and welding.Gas is turned off after 0.5S.</p> <p>4T:Press torch trigger to activate wire feeding.After arc ignition,start welding based on set wire feed speed.When releasing torch trigger,welding continues.Press torch trigger again,welding still continues.After releasing torch trigger,wire feeding and welding stops.Gas is turned off after 0.5S.</p>
	<p>Please refer to Section 4.7 MIG Gas for further parameter configuration.</p>

Welding parameters table (for reference only)

SOLID ER70S-6/Fe+CO2					
Material Thickness	1mm	2mm	3mm	4mm	5mm
WIRE DIA(φ)	Recommended Welding Current(V/A)				
.024"(0.6mm)	15.7/45	17.4/130			
.030"(0.8mm)	15.5/40	17.2/100	17.5/120	18/125	18.2/130
.035"(0.9mm)		17.9/100	18.1/130	18.3/130	19/130
.040"(1.0mm)		18.8/100	19.8/130	20.7/130	19.5/130
SOLID ER70S-6/Fe+MIX					
Material Thickness	1mm	2mm	3mm	4mm	5mm
WIRE DIA(φ)	Recommended Welding Current(V/A)				
.024"(0.6mm)	15.5/45	17.0/130			
.030"(0.8mm)	15.5/40	17.2/100	17.5/120	19.0/125	20.5/130
.035"(0.9mm)		17.8/100	17.6/120	18.1/125	18.5/130
.040"(1.0mm)		18.8/100	18.8/120	19.6/125	20.5/130
AL+AR					
Material Thickness	AL	2mm	3mm	4mm	5mm
WIRE DIA(φ)	Recommended Welding Current(V/A)				
.040"(1.0mm)	ER5356	17.7/95	17.5/120	18.1/125	18.5/130
.040"(1.0mm)	ER4043	15.7/95	15.5/120	16.1/125	16.5/130

5.8 Installation and operation for Gasless self-shielded arc welding

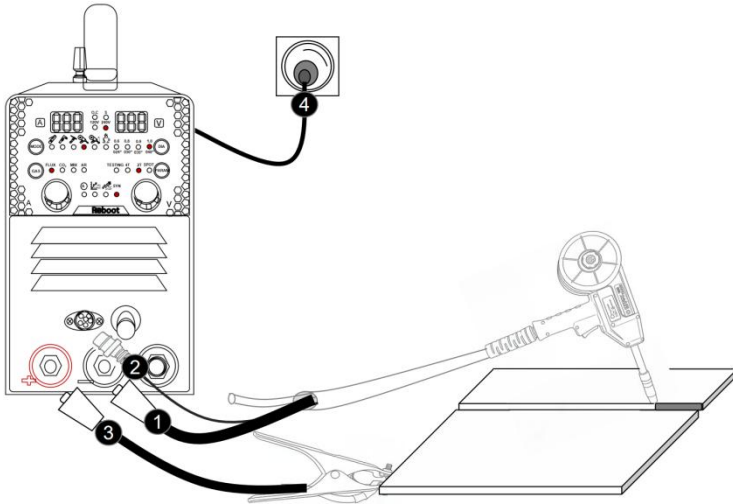

1	Connect the 10-25 EURO quick-connect plug of the Spool gun to the Negative(-) terminal on the machine's front panel and tighten it clockwise.
2	Connect the 6-pin aviation connector of the Spool gun to the corresponding port on the machine's front panel and tighten the locking nut.
3	Insert the cable plug with work clamp into the positive (+) output terminal on the front panel of the welding machine, and tighten it clockwise.
4	Connect the power ground well.

Install the wire spool on the spindle adapter and tighten the cover of spindle. Make sure that the groove size of wire feed roll matches the contact tip size of the welding torch and the wire diameter being used. Release the pressure arm of the wire feeder to thread the wire through the liner, into the rollgroove and then into the liner of central connector. Adjust the pressure arm to ensure no sliding of the wire. Too high pressure will lead to wire distortion, which will affect wire feeding. Press the Inching button to thread the wire out of the contact tip on the torch. (Gasless self-shielded arc welding applies flux-cored self-shielded welding wire, which requires knurling rolls). **Please refer to the welding Wire Installation section.**

Operation

1	After being installed according to the above method, and the power switch being switched on, the machine is started with digital display on and the fan
---	---

	working.
2	Select "Flux" as the welding mode.
3	Press torch trigger to activate wire feeding.After arc ignition,start welding based on set wire feed speed and voltage.Release torch trigger to stop wire feeding and welding

Note: The operation is the same as MIG operation except that there is no gas option.
Please refer to Section 4.6 MIG Gasless for further parameter configuration.

Welding parameters table (for reference only)

Material Thickness	1mm	2mm	3mm	4mm	5mm
WIRE DIA(ϕ)	Recommended Welding Current(V/A)				
.024"(0.6mm)	15.1/70	17.4/160	18.0/200		
.030"(0.8mm)	14.1/40	16.9/100	17.6/140	18.4/170	19.5/200
.035"(0.9mm)		16.4/100	17.2/140	17.8/170	18.5/200
.040"(1.0mm)		16.7/100	18.2/140	18.7/170	19.5/200

6. BASIC KNOWLEDGE OF WELDING

6.1 MMA/STICK/ARC

Manual metal arc welding, MMA for short, is an arc welding mode by manually operating electrode. Equipment for MMA is simple, convenient and flexible to be operated with high adaptability. MMA is applied to various metal materials with thickness more than 2mm and various structures, in particular to workpiece with complex structure and shape, short weld joint or bending shape, as well as weld joints in various spatial locations.

6.11 Welding Process of MMA

Connect the two output terminals of the welder to the workpiece and electrode holder respectively, and then clamp the electrode by the electrode holder. When welding, arc is ignited between the electrode and the workpiece, and the end of the electrode and part of the workpiece are fused to form a weld crater under the high-temperature arc. The weld crater is quickly cooled and condensed to form weld

joint which can firmly integrally connect two separate pieces of workpiece. The coating of the electrode is fused to produce slag to cover the weld crater. The cooled slag can form slag crust to protect the weld joint. The slag crust is removed at last, and the joint welding is finished.

6.12 Tools for MMA

- **Electrode holder**

a tool for clamping electrode and conducting current, mainly including 300A type and 500A type.

- **Welding mask**

a shielding tool for protecting eyes and face from injuring due to arc and spatter, including hand holding type and helmet type. Colored chemical glass is installed on the viewing window of the mask to filter ultraviolet ray and infrared ray. Arc burning condition and weld crater condition can be observed from the viewing window during welding. Thus, welding can be carried out by operators conveniently.

- **Slag hammer**

for the use of removing slag crust on the surface of weld joint.

- **Wire brush**

for the use of removing dirt and rust at the joints of the workpiece before welding, as well as cleaning the surface of weld and the spatter after welding.

- **Welding cable**

generally cables formed from many fine copper wires. Both YHH type arc welding rubber sleeve cable and THHR type arc welding rubber sleeve extra-flexible cable can be used. Electrode holder and welding machine are connected via a cable, and this cable is named as welding cable (live wire). Welding machine and workpiece are connected via another cable (earth wire). The electrode holder is covered with insulating material performing insulation and heat insulating.

6.13 Basic Operation of MMA

- **Welding joint cleaning**

Rust and greasy dirt at the joint should be removed completely before welding in order to implement arc igniting and arc stabilizing conveniently as well as ensure the quality of weld joint. Wire brush can be used for condition with low requirement on dust removal; grinding wheel can be used for condition with high requirement on dust removal.

- Posture in operating

Take flat welding of butt joint and T-shaped joint from left to right as an example (See below). The operator should stand at the right side of the working direction of weld joint with mask in the left hand and electrode holder in the right hand. The left elbow of the operator should be put on his left knee to prevent this upper body from following downwards, and his arm should be separated from the costal part so as to stretch out freely.

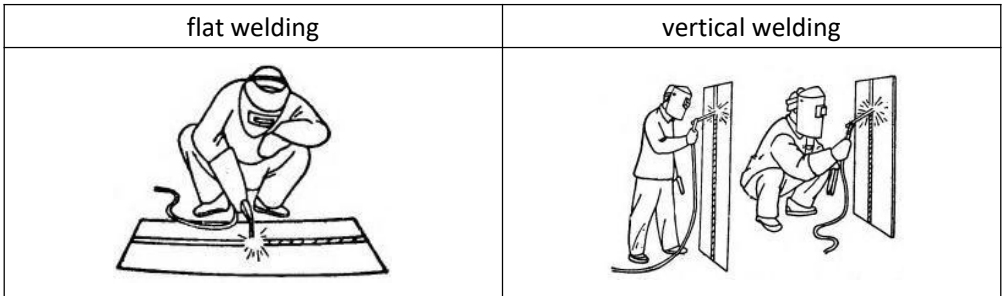

- Arc igniting

Arc igniting is the process for producing stable arc between electrode and workpiece in order to heat them to implement welding. Common arc ignition mode includes scraping mode and striking mode (See below). During welding, touch the surface of the workpiece with the end of the electrode by scraping or light striking to form short circuit, and then quickly lift the electrode 2~4mm away to ignite arc. If arc ignition fails, it is probably because there is coating at the end of the electrode, which affects the electric conduction. In this case, the operator can strongly knock the electrode to remove the insulation material until the metal surface of the core wire can be seen.

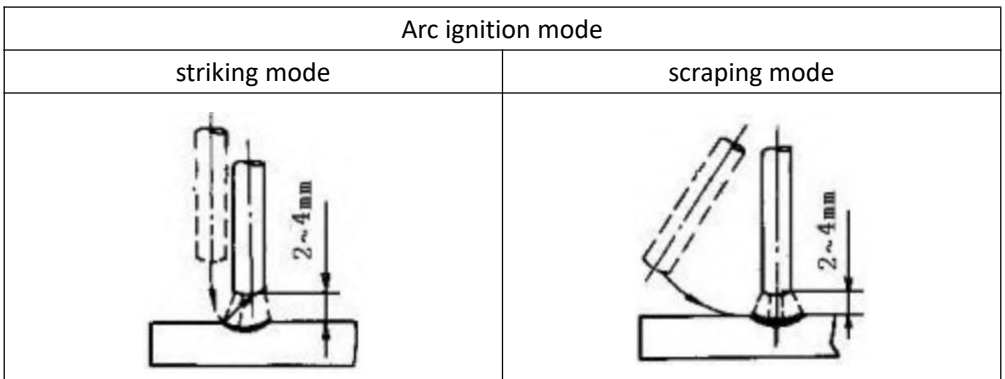

- **Tack weld**

For fixing the relative positions of the two pieces of weldment and welding conveniently,30~40mmshort weld joints are welded every certain distance in order to fix the relative positions of the workpiece during welding assembly.This process is named as tack weld.

- **Electrode manipulation**

The electrode manipulation actually is a resultant movement in which the electrode simultaneously moves in three basic directions:the electrode gradually moves along the welding direction;the electrode gradually moves toward the weld crater;and the electrode transversely swings.(See below figure)Electrode should be correctly manipulated in three movement directions after arc is ignited.In butt welding and flat welding,the most important is to control the following three aspects:welding angle,arc length and welding speed.

Welding angle:

the electrode should be inclined in 70~80°forwards as shown in the figure.

Arc length:

the proper arc length is equal to the diameter of electrode in general.

Welding speed:

proper welding speed should make the crater width of the weld bead about twice the diameter of the electrode,and the surface of the weld bead should be flat with fine ripples.If the welding speed is too high,and the weld bead is narrow and high,the ripples are rough,and the fusion is not well implemented.If the welding speed is too low,the crater width is excessive,and the workpiece is easy to be burned through. Besides,current should be proper,electrode should be aligned,arc should be low,and welding speed should not be too high and should be kept uniform during the whole welding process.

Three basic movement directions of electrode 1-downwards feed 2-move toward welding direction 3-transversely swing	Angles of electrode in flat welding
---	-------------------------------------

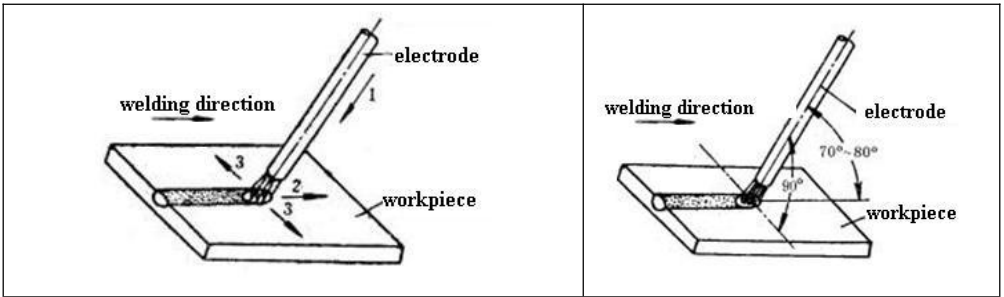

- Arc extinguishing

Arc extinguishing is unavoidable during welding. Poor arc extinguishing may bring shallow weld crater and poor density and strength of weld metal by which cracks, air holes, slag inclusion and the like are easy to be produced. Gradually pull the end of the electrode to the groove and raise the arc when extinguishing arc, in order to narrow the weld crater and reduce the metal and heat. Thus, defects such as cracks and air holes can be avoided. Pile up the weld metal of the crater to make the weld crater sufficiently transferred. Then, remove the excessive part after welding. The operation modes of arc extinguishing are shown in the figure below.

Arc extinguishing mode	
arc extinguishing at the outside of weld bead	arc extinguishing on the weld bead

- Weldment cleaning

Clean welding slag and spatter with wire brush and the like after welding.

6.2 Flux Cored Arc Welding(FCAW)

This is an electric arc welding process which fuses together the parts to be welded by heating them with an arc between a continuous flux filled electrode wire and the work. Shielding is obtained through decomposition of the flux within the tubular wire. Additional shielding may or may not be obtained from an externally supplied gas or gas mixture. The process is normally applied semi automatically; however the process may be applied automatically or by machine. It is commonly used to weld

large diameter electrodes in the flat and horizontal position and small electrode diameters in all position. The process is used to a lesser degree for welding stainless steel and for overlay work.

Weld at a Steady Pace do not weave the arc, neither forward, backward, or sideways remove slag with the Chipping Hammer to expose weld for Horizontal Weld Joints. Remember: Drag if there's Slag, Refer to manual for Troubleshooting Poor Weld Quality.

6.21 Adjustable Variables

- Stick-out

(distance between the end of the contact tube (tip) and the end of the electrode wire). Maintain at about 10mm stick-out.

- Wire Feed Speed

Increase in wire feed speed increases current, Decrease in wire feed speed decreases weld current.

- Nozzle Angle

This refers to the position of the welding gun in relation to the joint. The transverse angle is usually one half the included angle between plates forming the joint. The longitudinal angle is the angle between the center line of the welding gun and a line perpendicular to the axis of the weld. The longitudinal angle is generally called the Nozzle Angle and can be either trailing (pulling) or leading (pushing). Whether the operator is left handed or right handed has to be considered to realize the effects of each angle in relation to the direction of travel.

Establishing the Arc and Making Weld Beads

1. Before attempting to weld on a finished piece of work, it is recommended that practice welds be made on a sample metal of the same material as that of the finished piece.
2. The easiest welding procedure for the beginner to experiment with MIG welding is the flat position. The equipment is capable of flat, vertical and overhead positions.
3. For practicing MIG welding, secure some pieces of 1.5mm or 2.0mm mild steel plate 150X150mm. Use 0.8mm flux cored gas less wire or a solid wire with shielding gas.

6.22 Basic MIG Welding

Good weld quality and weld profile depends on gun angle, direction of travel,

electrode extension(stick out), travel speed, thickness of base metal, wire feed speed(amperage) and arc voltage. To follow are some basic guides to assist with your setup.

1) Gun Position -ravel Direction, Work Angle

Gun position or technique usually refers to how the wire is directed at the base metal, the angle and travel direction chosen.Travel speed and work angle will determine the characteristic of the weld bead profile and degree of weld penetration.

(A)Push Technique

The wire is located at the leading edge of the weld pool and pushed towards the un-melted work surface.This technique offers a better view of the weld joint and direction of the wire into the weld joint.Push technique directs the heat away from the weld puddle allowing faster travel speeds providing a flatter weld profile with light penetration -useful for welding thin materials.The welds are wider and flatter allowing for minimal clean up /grinding time.

(B)Perpendicular Technique

The wire is fed directly into the weld,this technique is used primarily for automated situations or when conditions make it necessary.The weld profile is generally higher and a deeper penetration is achieved.

(C)Drag Technique

The gun and wire are dragged away from the weld bead.The arc and heat are concentrated on the weld pool,the base metal receives more heat,deeper melting,more penetration and the weld profile is higher with more build up.

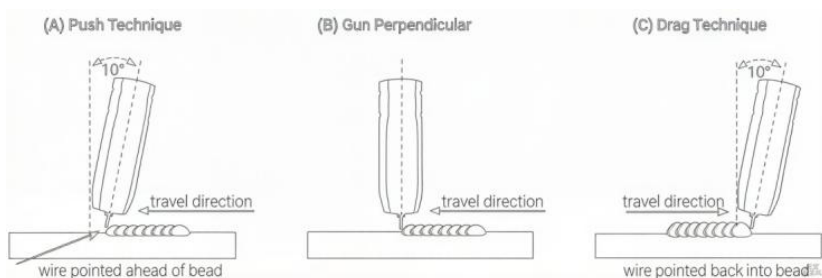

2) Travel Angel

Travel angle is the right to left angle relative to the direction of welding. A travel angle of 5° - 15° is ideal and produces a good level of control over the weld pool. A

travel angle greater than 20° will give an unstable arc condition with poor weld metal transfer, less penetration, high levels of spatter, poor gas shield and poor quality finished weld.

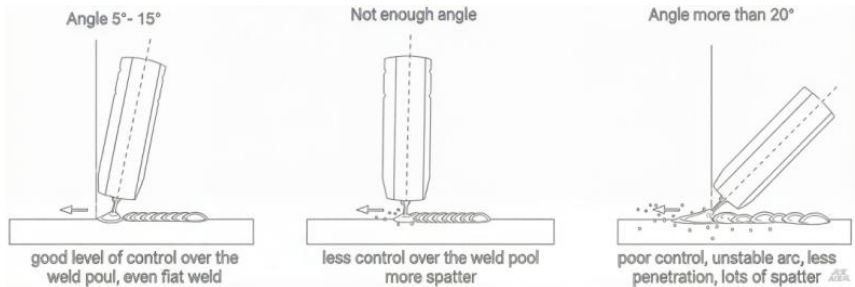

3) Angle to Work

The work angle is the forward back angle of the gun relative to the work piece. The correct work angle provides good bead shape, prevents undercut, uneven penetration, poor gas shield and poor quality finished weld.

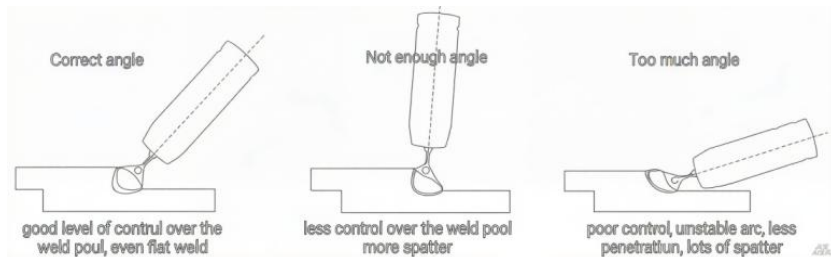

4) Stick Out

Stick out is the length of the unmelted wire protruding from the end of the contact tip. A constant even stick out of 5-10mm will produce a stable arc, and an even current flow providing good penetration and even fusion. Too short stick out will cause an unstable weld pool, produce spatter and over heat the contact tip. Too long stick out will cause an unstable arc, lack of penetration, lack of fusion and increase spatter.

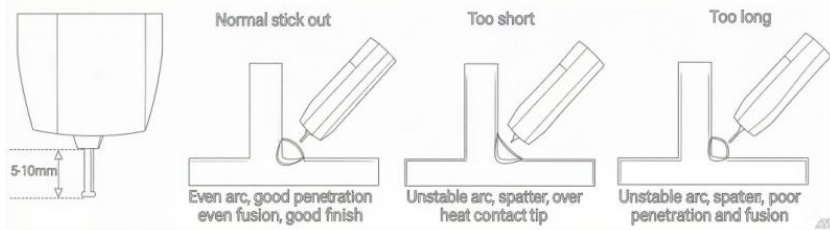

6.23 Travel Speed

Travel speed is the rate that the gun is moved along the weld joint and is usually measured in mm per minute. Travel speeds can vary depending on conditions and the welders skill and is limited to the welders ability to control the weld pool. Push technique allows faster travel speeds than Drag technique. Gas flow must also correspond with the travel speed, increasing with faster travel speed and decreasing with slower speed. Travel speed needs to match the amperage and will decrease as the material thickness and amperage increase.

- Too Fast Travel Speed

A too fast travel speed produces too little heat per mm of travel resulting in less penetration and reduced weld fusion, the weld bead solidifies very quickly trapping gases inside the weld metal causing porosity. Undercutting of the base metal can also occur and an unfilled groove in the base metal is created when the travel speed is too fast to allow molten metal to flow into the weld crater created by the arc heat.

- Too Slow Travel Speed

A too slow travel speed produces a large weld with lack of penetration and fusion. The energy from the arc dwells on top of the weld pool rather than penetrating the base metal. This produces a wider weld bead with more deposited weld metal per mm than is required resulting in a weld deposit of poor quality.

- Correct Travel Speed

The correct travel speed keeps the arc at the leading edge of the weld pool allowing the base metal to melt sufficiently to create good penetration, fusion and wetting out of the weld pool producing a weld deposit of good quality

6.3 GMAW

Gas-shielded arc welding is an arc welding process that uses gas as both the arc medium and a protective shield for the arc and weld zone. It is an open-arc welding

method and generally does not employ flux-cored wires. This process offers high productivity and broad applicability.

Gas-shielded arc welding can be divided into two main types: non-consumable electrode (tungsten) inert gas arc welding (TIG) and gas metal arc welding (GMAW). Metal inert gas arc welding (MIG) is a welding process that uses a continuously fed consumable wire electrode and an inert gas shield. It is one of the most commonly used methods in automotive sheet metal repair and is primarily applied to welding relatively active metals such as stainless steel, heat-resistant alloys, copper alloys, and aluminum-magnesium alloys.

6.31 Classification and application of GMAW

According to the type of shield gas, the form of welding wire and the mode of operation, GMAW can be divided into several categories as below:

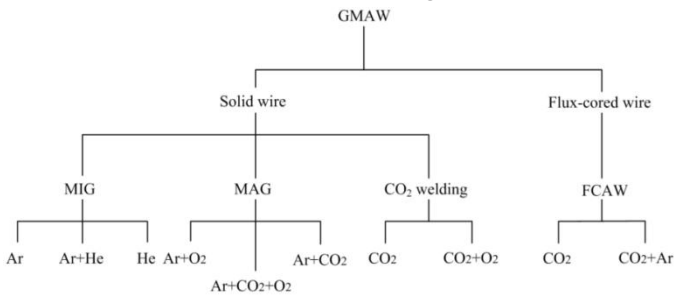

- GMAW is suitable for welding most metals and alloys, and is particularly well-suited for carbon steel, low-alloy steel, stainless steel, aluminum, copper, magnesium, and their alloys.
- For metals with high melting points, such as high-strength steel and high-strength aluminum alloys, appropriate pre-weld procedures are required.
- GMAW is not recommended for metals with low melting points.
- The minimum achievable weld thickness is 1 mm.
- It offers high adaptability to various welding positions.

6.32 GMAW Welding Equipment

- Power Source:GMAW typically uses a DC power source. The required power rating depends on the desired welding current range for the specific application.
- Wire Feed System:The wire feed system generally consists of a feeder (including a motor, gear reducer, guide rollers, and drive rolls), a feed conduit (liner), a wire spool, and associated components.

- **Welding Torch:**GMAW torches are categorized as either semi-automatic or automatic. Semi-automatic torches are further classified by their cooling method: air-cooled or water-cooled

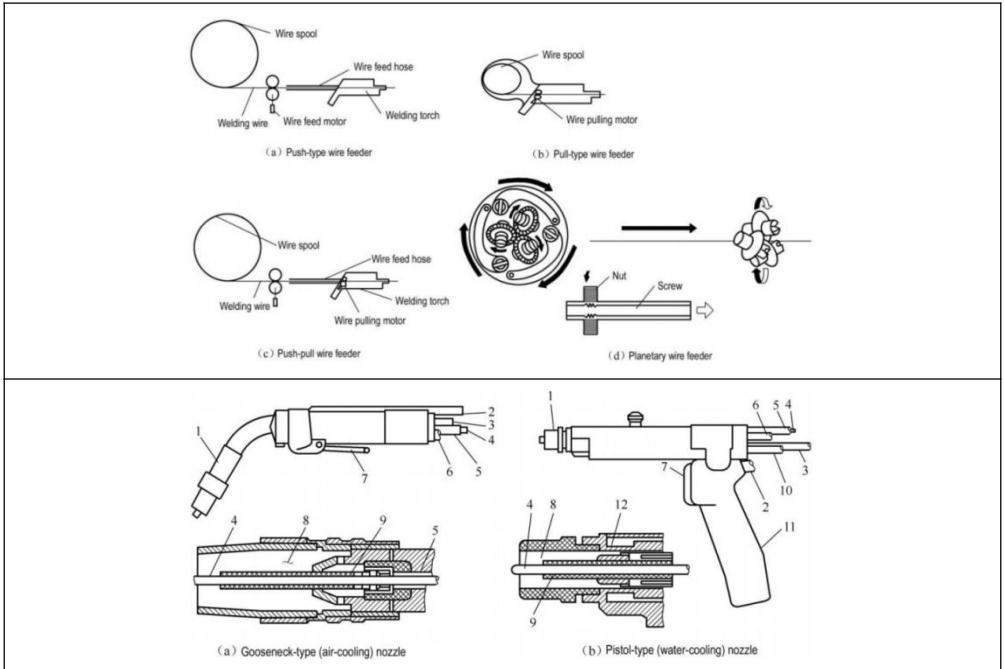

6.33 Basic Operation of GMAW

A. Pre-weld Preparation

1. Cleaning: Remove all contaminants (oil, grease, rust, oxide layers) from the joint area using appropriate chemical or mechanical methods (e.g., grinding, wire brushing).

2. Equipment Check:

- Visually inspect the welder, torch, cables, and gas system for damage.
- Verify electrical connections, grounding, and that the correct gas and consumables (wire type/diameter) are installed for the base material and process.
- Perform a test run to ensure wire feeding, gas flow, and electrical output are functioning correctly.

B. Personal Protective Equipment (PPE)

Operators must wear:

- A welding helmet with proper shade lens.
- Flame-resistant (FR) clothing (jacket, gloves) to protect from sparks and heat.
- Safety glasses under the helmet.
- Sturdy leather boots or shoes.

C. Welding Parameter Selection & Effects

Key adjustable parameters and their effects are summarized below:

Parameter	Definition & Primary Effect	Guideline / Consideration
Wire Feed Speed (WFS)	Controls the welding current and deposition rate. Higher WFS = higher amperage.	Set first based on material thickness and desired penetration. The voltage must then be adjusted to match.
Voltage	Controls the arc length and weld bead width. Higher voltage = longer, wider arc.	Adjusted to match WFS. Affects bead profile and fusion. Incorrect voltage causes poor arc stability (spatter or stubbing).
Travel Speed	Speed the torch moves along the joint.	Affects penetration and bead shape. Too slow = excessive heat/weld metal. Too fast = poor penetration/undercut.
Electrode Extension (Stick-out)	Length of unmelted wire beyond the contact tip.	Affects resistive heating. Longer = hotter wire melt-off, less penetration. Typically 10-15 mm (3/8" to 5/8").
Torch Angle	Angle of the torch relative to the direction of travel and workpiece.	Travel Angle: Tilt in the direction of travel. Work Angle: Tilt perpendicular to travel. Affects penetration depth, bead shape, and shielding gas coverage.

Note on Stick-out: A longer stick-out increases resistive (I^2R) heating in the wire, raising its melt-off rate. This can reduce penetration as more energy is used to melt the wire instead of the base metal. Excessively long stick-out can also lead to poor arc stability and irregular wire feeding.

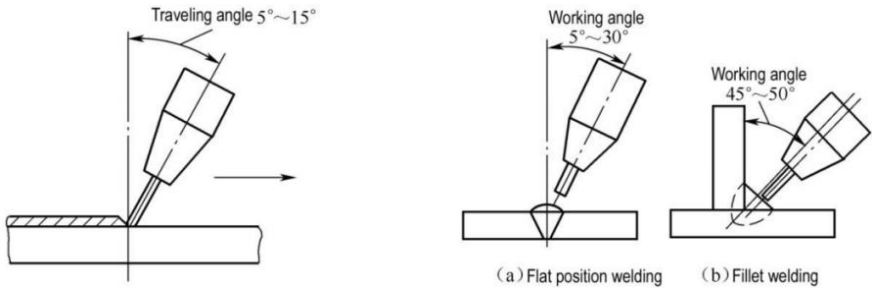

The influence of torch position on weld bead geometry is illustrated in the figure above.

When the torch is tilted from a vertical position to a backward (drag) angle, with all other parameters held constant, the weld penetration increases, the bead narrows, reinforcement height rises, and the arc tends to be more stable with reduced spatter. Maximum penetration is typically achieved with a travel angle of approximately 25 degrees in the backward direction. For improved control of the weld pool, a travel angle between 5 and 15 degrees is generally recommended. When making horizontal fillet welds, a work angle of 45 degrees is standard.

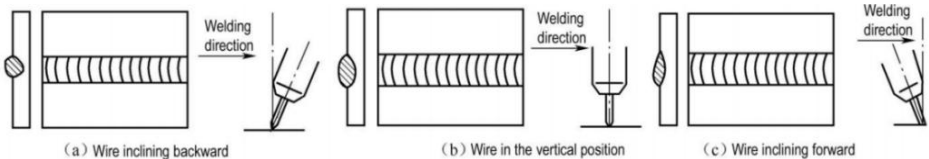

1) Welding Position

GMAW is suitable for welding in the following positions: flat, vertical, overhead, as well as uphill and downhill welding on inclined surfaces.

2) Shielding Gas Flow

Shielding gas exiting the nozzle can exhibit two flow states: a stable, thicker laminar flow or a thinner flow closer to turbulence. Typically, a nozzle with an inner diameter of 12 mm is used, with a recommended gas flow rate of 8–15 L/min.

c. Arc Ignition

Gas-shielded arc welding typically uses contact (short-circuit) arc ignition. Before striking the arc, set the electrode extension to the proper length. During ignition, ensure the wire is not in direct contact with the workpiece; maintain a distance of 2–3 mm. If a large ball forms at the wire tip, trim it off before proceeding.

d. Welding

For details on the MIG welding procedure—including tacking, weld start, electrode manipulation techniques, weld restart (crater filling), and weld termination—please refer to the relevant sections of the operating manual.

e. Arc Termination (Crater Fill)

Do not terminate the arc abruptly at the end of a weld, as this can leave a crater that may develop cracks or porosity. To properly finish, pause briefly at the crater to fill it, then slowly withdraw the torch while maintaining gas coverage until the weld pool solidifies.

f. Weld Restart (Tie-in)

The weld restart is generally performed using a backstep technique. The operation is similar to that used in shielded metal arc welding (SMAW).

g. Forehand vs. Backhand Technique

GMAW is typically performed using the forehand (push) technique.

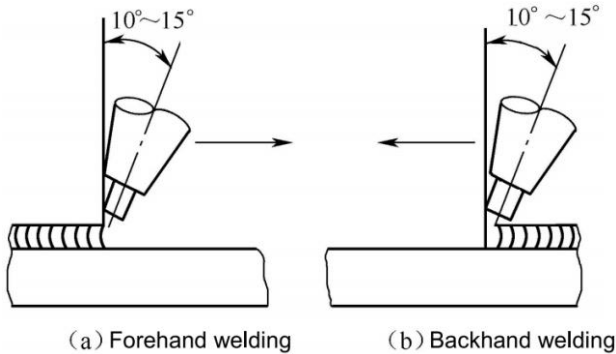

h. Electrode Manipulation

There are two basic manipulation modes: straight progression (stringer bead) and transverse oscillation.

- Straight Progression produces a narrow bead and is mainly used for sheet metal welding and root passes.
- Transverse Oscillation involves moving the electrode side-to-side across the weld centerline during travel. Common oscillation patterns include zigzag, crescent, and circular motions. The specific techniques are similar to those used in SMAW.

6.34 Welding in Different Positions

- Flat Position Welding

Flat position welding typically uses the forehand (push) technique with a travel angle of 10–15°. For welding thin sheet metal and for root (backing) passes, a straight progression (stringer bead) is used. For filling grooves in multi-pass welds, a transverse weaving (oscillation) technique can be employed.

- **Welding T-Joints and Lap Joints**

When welding T-joints, defects such as undercut, lack of fusion, and sagging are common. The torch angle should be adjusted according to the plate thickness and required fillet weld size to prevent these issues. For a horizontal fillet weld joining plates of different thicknesses, direct the arc slightly toward the thicker plate to ensure balanced heat input and fusion in both members.

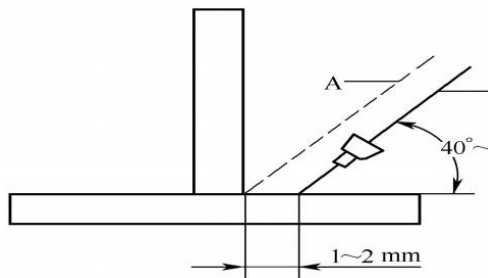

- **Vertical Position Welding**

GMAW can be performed in the vertical position using two primary techniques: vertical-up (uphill) and vertical-down (downhill).

Vertical-Up Welding: In this technique, molten metal tends to sag downward due to gravity. The arc force can lead to disadvantages such as excessive penetration and a narrow, convex bead profile. Consequently, this technique is less commonly used for GMAW.

Vertical-Down Welding: This is the more frequently used technique for vertical GMAW, offering better control of the weld pool and appearance.

- **Horizontal Position Welding**

The parameters for horizontal (2G) position welding are similar to those for vertical position welding. However, the welding current can typically be set slightly higher for the horizontal position.

6.4 plasma cutting

6.4.1 Pilot Cutting

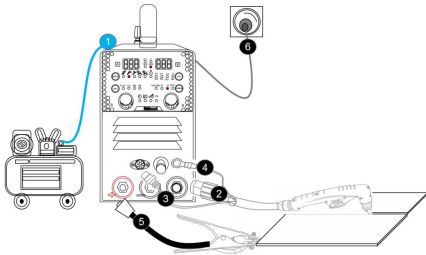
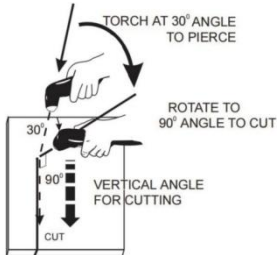
 <p>The diagram shows a plasma cutter unit with various controls and connections. A blue cable is connected to the top. A power cord is plugged into a wall outlet. A ground clamp is attached to the bottom of the unit. A torch is connected to the side. A workpiece is being cut by the torch. Numbered callouts 1 through 6 point to specific components: 1. Output current control knob, 2. Ground clamp, 3. Torch, 4. Gas control knob, 5. Power switch, 6. Power cord.</p>	 <p>The diagram illustrates the correct torch angles for pilot cutting. It shows a hand holding the torch at a 30-degree angle to the workpiece, labeled 'TORCH AT 30° ANGLE TO PIERCE'. An arrow indicates the direction to 'ROTATE TO 90° ANGLE TO CUT'. A vertical dashed line is labeled 'VERTICAL ANGLE FOR CUTTING'. The resulting cut is shown as a vertical line labeled 'CUT'.</p>
<ol style="list-style-type: none">1. Confirm that plasma cutter has been installed and operated correctly.2. Clamp the Ground clamp onto the workpiece, The Ground clamp must be securely connected to the workpiece.3. Set the output current control knob at maximum position for higher cutting speed and less dross formation. Reduce the current, if desired to reduce the cut width, heat affected zone or travel speed as required.	<ol style="list-style-type: none">1. When ready to cut, place the torch near the work, make certain all safety precautions have been taken and pull the trigger. The pilot arc will start.2. Pierce the work piece by slowly lowering the torch onto the metal at a 30° angle away from the operator. <p>This will blow the dross away from the torch nozzle. Slowly rotate the torch to vertical position as the arc becomes deeper.</p> <p>NOTE: Graphics shown are for understanding torch angles for best results – the distances from the workpiece are exaggerated. In actual operation, the nozzle should be held just above the work piece surface.</p>

6.4.2 Optimized Operation Guidelines

Torch Control & Nozzle Use

- For improved stability, you may lightly drag the nozzle along the workpiece surface. Note: This will reduce nozzle life.
- Alternatively, a non-conductive guide or standoff can be used to maintain a consistent distance for a cleaner cut.

Postflow & Trigger Operation

- Releasing the trigger stops the arc. Postflow gas continues for 5 seconds to cool

the torch.

- If the trigger is pulled again within this period, the arc will re-strike immediately.

Cutting Quality Adjustments

- If dross is difficult to remove, reduce the cutting speed. High-speed dross is typically harder to clean than low-speed dross.
- When viewed in the direction of travel, the right side of the kerf is generally squarer than the left side.

Maintenance

- Regularly clean spatter and scale from the nozzle to maintain cut quality and extend consumable life.

6.4.3 Parts in place

Torch Consumables Inspection & Maintenance

1. Assembly Check

- Verify that all torch consumables are correctly assembled and seated. Improper assembly will prevent the machine from starting.
- Ensure the shield cup is hand-tight only. Do not use tools or over-tighten.

2. Nozzle Inspection & Cleaning

- Inspect the nozzle interior. If debris is present, lightly rotate the electrode inside the nozzle bottom to remove any oxide buildup. (See “Routine Maintenance” for details.)

3. Electrode Inspection

- Check the electrode tip. A cratered appearance indicates wear; replace both the electrode and nozzle as a set.
- Maximum allowable wear depth is approx. 0.062” (~1.6 mm).
- A green, erratic arc confirms electrode failure. Replace immediately.

4. Nozzle Replacement

- Replace the nozzle if the orifice is eroded, enlarged, or oval-shaped.

6.4.4 Pilot Arc Operation & Guidelines

1. Function & Design

The CUT system produces a smooth, continuous pilot arc. This arc serves solely to transfer the main cutting arc to the workpiece and is not intended for repeated, non-cutting ignition cycles.

2. Recommended Practice

- Avoid rapid, successive pilot- arc starts, as this shortens consumable life.
- The pilot arc is optimized for reliable transfer to the workpiece, not for frequent ignition without cutting.

3. Normal Operation & Indicators

- A slight mechanical impulse in the torch handle is normal upon pilot- arc initiation. This is part of the arc- starting mechanism.
- This impulse can also serve as a useful diagnostic indicator when troubleshooting a "no- start" condition.

4. Troubleshooting Note

If the pilot arc sputters or starts intermittently, common causes include:

- Worn consumables (electrode/nozzle).
- Excessively high air pressure.





6.4.5 Notes for cutting operation





WARNING



BEWARE OF ELECTRIC SHOCK!

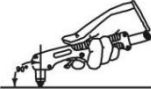

	Avoid unnecessary arc ignition in air, as this will shorten the torch electrode and nozzle life. If the torch trigger is held for more than 3 seconds without contacting the workpiece, the arc will automatically shut off.
	For best results, start the cut from the edge of the workpiece unless piercing is required.
	Proper cuts are indicated by spatter exiting from the bottom of the workpiece. If spatter is observed coming from the top, it indicates incomplete penetration. This is typically caused by excessive travel speed or insufficient cutting current.
	Maintain light contact between the nozzle and workpiece, or a small standoff distance. Pressing the torch firmly against the workpiece can cause the nozzle to stick and result in an uneven cut.

	<p>When cutting round workpieces or when precise cuts are required, the use of a fixture, template, or other positioning aids is recommended.</p>
	<p>The preferred technique is to drag the cutting torch along the direction of travel.</p>
	<p>Torch Operation & Safety</p> <ol style="list-style-type: none"> 1. Torch Position & Arc Tracking Hold the torch so the nozzle is perpendicular to the workpiece surface. Visually confirm the arc is centered on and tracking your cut line. 2. Cable Management Do not sharply bend, step on, or pinch the torch cable—especially in confined spaces. Keep the cable clear of sharp edges, hot surfaces, and moving parts. 3. Gas Flow Warning Restricting the cable can block gas flow, leading to insufficient cooling. This may overheat and damage the torch.
	<p>Nozzle & Torch Head Cleaning</p> <ol style="list-style-type: none"> 1. Standard Maintenance Instructions To maintain optimal thermal performance, promptly remove spatter buildup from the nozzle, as it can insulate heat and reduce cooling efficiency. After each use, also clean dust and spatter from the torch head to ensure consistent heat dissipation. 2. Concise Daily Checklist After use: Clean all spatter and dust from the torch head and nozzle. Why: Debris acts as an insulator, reducing cooling and risking torch damage. 3. Detailed Procedure Regular spatter removal is critical for torch longevity. Spatter on the nozzle creates a thermal barrier that inhibits cooling, while

	accumulation on the torch head restricts airflow. Clean both areas thoroughly at the end of each workday.
--	---

The workpiece is not cut fully. This may be caused by:

1. The cutting current is too low.
2. The cutting speed is too high.
3. The electrode and nozzle of the torch are burned.
4. The workpiece is too thick.

Molten slag drops from the bottom of workpiece. This may be caused by:

1. The cutting speed is too low.
2. The electrode and nozzle of the torch are burned.
3. The cutting current is too high.

7. MAINTENANCE

<p>WARNING</p> 	<p>The following operation requires sufficient professional knowledge on electric aspect and comprehensive safety knowledge. Operators should be holders of valid qualification certificates which can prove their skills and knowledge. Make sure the input cable of the machine is disconnected from the electricity utility before uncovering the welding machine.</p>
1	<p>Check periodically whether inner circuit connection is in good condition, connector is fastened (esp. plugs or components). Tighten the loose connection. If there is rust or oxidization, remove it with sandpaper and then reconnect tightly.</p>
2	<p>Don't let hands, hair or other tools contact live parts when machine is powered on, e.g., fan, so that to avoid any injury or machine damage.</p>
3	<p>Clean periodically the dust with dry compressed air whose pressure should be at a proper level in order to avoid the small parts inside the machine being damaged. If welding environment with heavy smoke and pollution, the machine should be cleaned every day.</p>
4	<p>Avoid water or vapor entering machine inside; in case it happens, please dry the machine internal structure. Then use a mega-meter to test machine's insulation (including wire to wire connection and wire to machine enclosure</p>

	connection.).Welding can be continued only after the confirmation of normal.
5	Check periodically whether the insulation cover of all cables is in good condition.If there is any dilapidation,rewrap it or replace it.
6	Put the machine into the original packing in dry location if it is not to be used for a long time.

Routine and Periodic Maintenance

1	Before Each Use -Check over machine and accessories for any obvious condition that may prevent safe performance or operation,repair or replace items as necessary to correct any abnormal condition.
2	AFTER 5 MINUTES OF WELDING OR WHEN SPATTER ACCUMULATES ON THE CONTACT TIP: Cleaning Tip and Nozzle- With the power switch in the OFF position,keep the contact tip and nozzle clean to avoid are bridging between them. Bridging can result in a shorted nozzle, poor welds and an overheated gun. Hint:Anti-stick spray or gel, available from a welding supplier, may reduce buildup and aid in spatter removal.

Daily maintenance

The power of the switching box and the welding machine should be shut down before daily checking (except appearance checking without contacting the conductive body) to avoid personal injury accidents such as electric shock and burns.

1	Daily checking is very important in keeping the high performance and safe operation of this welding machine.
2	Do daily checking according to the table below, and clean or replace components when necessary.
3	In order to ensure the high performance of the machine, please choose components provided or recommended by producer when replacing components.

Daily checking of the welding machine

Items	Items	Items
Front panel	Whether any of the components are damaged or loosely connected; Whether the output quick sockets are tightened;Whether the abnormality indicator	If unqualified, check the interior of the machine, and tighten or replace the

	illuminates.	components.
Back panel	Whether the input power cable and buckle are in good condition;Whether the air intake is unobstructed.	
Cover	Whether the bolts are loosely connected.	If unqualified, tighten or replace the components.
Chassis	Whether the screws are loosely connected.	
Routine	Whether the machine enclosure has color fading or overheating problems; Whether the fan sounds normal when the machine is running; Whether there is abnormal smell, abnormal vibration or noise when the machine is running.	If abnormal, check the interior of the machine.
Cleaning the Feed Rolls	Clean the grooves in the drive rolls frequently.This can be done by using a small wire brush.Also wipe off, or clean the grooves on the upper feed roll. After cleaning,tighten the feed roll retaining knobs.	
Earth cable	Whether the grounding wires (including workpiece Earth wire and welding machine earth wire) break off.	If unqualified, tighten or replace the components.
Welding cable\ MIG gun	Whether the insulating layer of the cable is worn, or the conductive part of the cable is exposed; Whether the cable is drawn by an external force; Whether the cable connected to the workpiece is well connected.	Use appropriate methods according to the work site situation to ensure safety and normal cutting.

8.TROUBLESHOOTING

<p>WARNING</p> 	<p>Service and Repair should only be performed by qualified authorized personnel; Unauthorized repairs performed on this equipment may result in danger to the technician and machine operator and will invalidate your factory warranty. For your safety and to avoid Electrical Shock, please observe all safety noted and precautions detailed throughout this manual.</p>
<p>When replacing parts, use only original spare parts. When ordering spare parts, please quote the machine type, serial number and item number of the machine, as well as the type designation and item number of the spare part.</p>	
<p>This Troubleshooting Guide is provided to help you locate and repair possible machine malfunctions. Simply follow the three step procedure listed below.</p>	
<p>1) Locate Problem(Symptom) Look under the column labeled “PROBLEM(SYMP TOMS)”. This column describes possible symptoms that the machine may exhibit. Find the listing that best describes the symptom that the machine is exhibiting.</p> <p>2) Possible Cause The second column labeled “POSSIBLE CAUSE” lists the obvious external possibilities that may contribute to the machine symptom.</p> <p>3) Recommended Course of Action This column provides a course of action for the Possible Cause, generally it states to contact you local after-sales service center. If you do not understand or are unable to perform the Recommended Course of Action safely, contact your local after-sales service center.</p> <p>4) Electric Shock can kill Turn off machine at the disconnect switch on the rear of the machine and remove main power supply connections before doing any troubleshooting.</p>	
<p>1</p>	<p>Problem(Symptom)</p>
<p>Bead is too thick(intermittently)</p>	
<p>Possible Cause</p>	<p>Recommended Course of Action</p>
<p>Travel speed is slow and/or inconsistent</p>	<p>Increase and maintain a constant travel speed</p>

Output heat range is too high	Set the knob to low
2	Problem(Symptom)
Bead does not penetrate base metal	
Possible Cause	Recommended Course of Action
Travel speed is inconsistent	Decrease and maintain a constant travel speed
Output heat range is too low	Set the knob to high
3	Problem(Symptom)
Wire sputters and sticks to workpiece	
Possible Cause	Recommended Course of Action
The wire is damp	Change to dry wire.Be sure wire is stored in a dry location
Wire feed speed is too fast	Reduce wire feed speed
4	Problem(Symptom)
Edge of weld has ragged depressions	
Possible Cause	Recommended Course of Action
Travel speed is too fast	Reduce travel speed
Wire feed speed is too fast	Reduce wire feed speed
Output heat range is too high	Set the knob to low
5	Problem(Symptom)
There is no current after turning on the machine	
Possible Cause	Recommended Course of Action
The power cord is not well connected	Reconnect the power cord
The welding machine fails	Ask professionals to check
6	Problem(Symptom)
The fan does not work during welding	
Possible Cause	Recommended Course of Action
The power cord for the fan is not well connected	Reconnect the power cord for the fan
Auxiliary power fails	ask professionals to check
7	Problem(Symptom)
The overheating indicator is on	

Possible Cause	Recommended Course of Action
The overheating protection circuit works	It can be recovered after the machine cools down
8	Problem(Symptom)
There is no response when pushing the torch trigger and the alarm indicator does not illuminate.	
Possible Cause	Recommended Course of Action
The torch trigger fails	Repair or replace the welding torch
9	Problem(Symptom)
When the torch trigger is pushed, there is gas output, but there is no output current, and the alarm indicator does not illuminate	
Possible Cause	Recommended Course of Action
The earth cable is not well connected with the workpiece	Reconnect it
The torch trigger fails	Repair or replace the welding torch
10	Problem(Symptom)
There is output current when pushing the torch trigger to feed gas, but the wire feeder does not work	
Possible Cause	Recommended Course of Action
The wire feeder is clogged	Unclog it
11	Problem(Symptom)
The welding current is unstable	
Possible Cause	Recommended Course of Action
The wire feeder fails	Repair it
The control PCB or wire feeding power PCB inside the machine fails	Replace it
The pressure arm on the wire feeder is not properly adjusted	Adjust it to get proper pressure
The drive roll does not match the wire size being used	Make sure they match with each other
The contact tip of the welding torch is badly worn	Replace it
The wire-feeding tube of the welding	Replace it

torch is badly worn	
The electrode is of poor quality	Use electrode of good quality

9.ELECTRICAL SCHEMATIC DIAGRAM

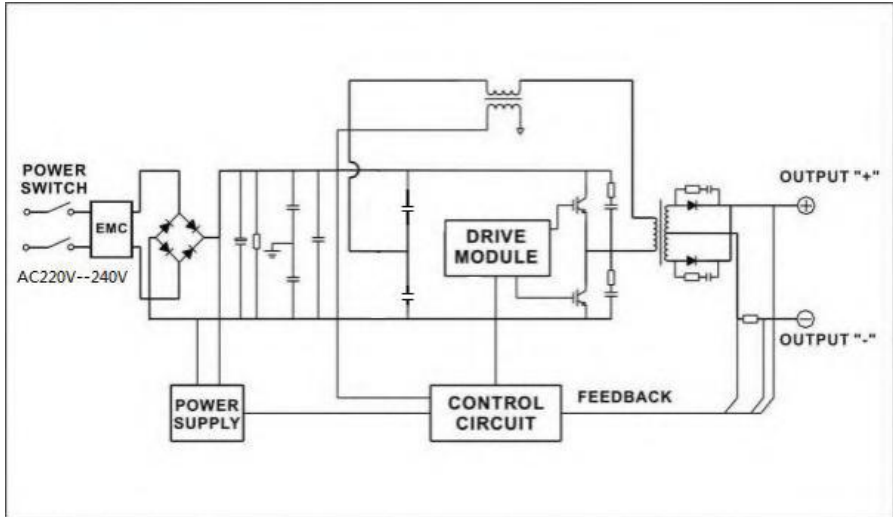

10. Warranty Registration

To ensure optimal performance and consistency, we recommend purchasing genuine spare parts exclusively from the official REBOOT website. You may also register your product there to activate your warranty.

Official Website:

<https://www.rebootec.com>

Warranty Registration

REBOOTEK Warranty Registration

Accurately fill in the following information for warranty registration

* First Name	*Last Name
* Email	
* Phone Number	
Serial Number of Machine	
* Order Number	